

CPS SERIES

Pallet Scale

Pallet car with Electronic Scale
Saving time with Carrying and Weighing at once



CPS SERIES Pallet Scale

FEATURES

- Easy Operation
- Putting down the fork in stable with Oil Pressure
- Saving time with Carrying and Weighing at once
- Using Oil Pressure for putting down the fork in stable
- Versatile for any size room
- Heavy Duty for any size job

SPECIFICATIONS

Model	CPS-1	CPS-2
Weighing Capacity	1000 ×0.5kg	2000 ×1 kg
Measurement Type	CI-2001B, Load Cell	
Power Source	Rechargeable Battery, AC 110/220V	
Display Type	5 Digit LCD (Height 25mm)	
Display Designators	ON/OFF, Zero, Tare, kg/lb	
Accessory	Rechargeable Battery, AC adaptor	
Option	RS-232C, Resolution1/2000	

INDICATOR(CI-2001B)



DIMENSIONS

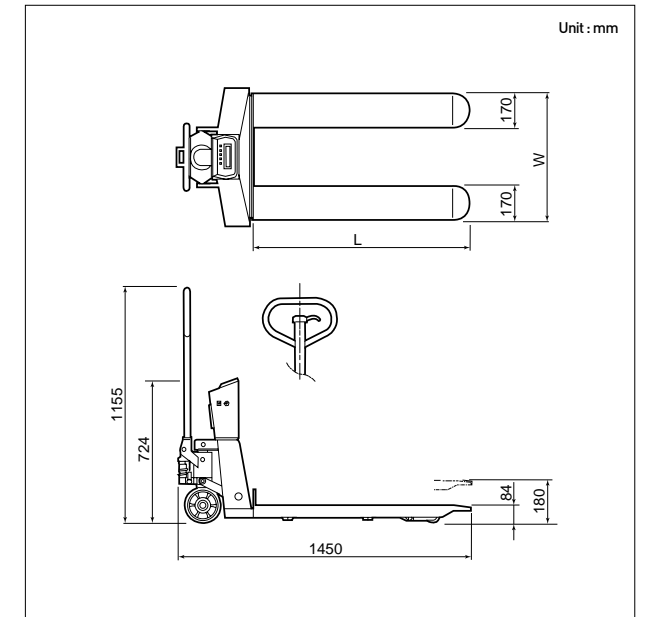

Unit : mm

Model	CPS-1			CPS-2			
	TYPE	A	B	C	A	B	C
Size	W	540	620	705	540	620	705
	L	1080	1080	1200	1080	1080	1200



CAS BLDG., # 440-1, SUNGNAE DONG,
GANGDONG GU, SEOUL, KOREA
TEL_ 82 2 2225 3500
FAX_ 82 2 475 4668
<http://www.globalcas.com>

Specifications are subject to change for improvement without prior notice.