

Caston II

Crane Scale

- Available in 500 × 0.2 kg, 1000 × 0.5 kg, or 2000 × 1 kg Capacities
- Battery Operated
- Easy to Read 1.2" LED Display
- Wireless Remote Control Standard



CAS

CASTON II Crane Scale

FEATURES

- Battery Operated w/ Low Battery Indication
- Rechargeable Battery Pack
- Spare Battery Pack and Charger Included as Standard
- Remote Control Included as Standard
- On, Off, Zero, Tare, and Hold (Manual or Automatic) Functions
- Easy to Read 1.2" LED Display
- Auto Span Adjustment
- Auto Zero Tracking

SPECIFICATIONS

Model	0.5 THB	1 THB	2 THB	3 THB
Weighing Capacity	500×0.2kg	1000×0.5kg	2000×1kg	3000×2kg
Maximum Tare	Full Tare			
Display Type	LED(1.2 inch)			
Operating Power	DC 6 V			
Power Source	AC 110/120/220/240 V, 50 / 60 Hz			
Display Designators	Zero, Tare, Hold, Batt.			
Power Consumption	1 W			
Operating Temperature	-10°C ~ +40°C			
Product Weight	17 kg			

DIMENSIONS

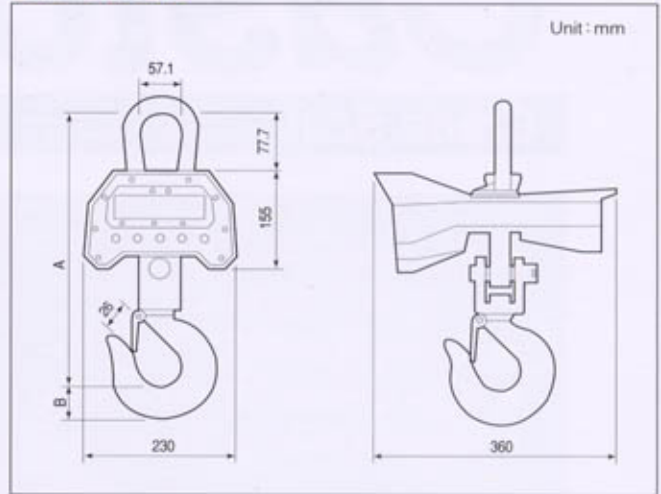

Model	A	B
0.5 THB	350	30
1 THB	350	30
2 THB	430	44.5
3 THB	430	44.5



▲ Display & Key board



▶ Battery Pack Installation

CAS

CAS BLDG., # 440-1, SUNGNAE - DONG,
GANGDONG - GU, SEOUL, KOREA
TEL : 82-2-475-4661 / 7, FAX : 82-2-475-4668
TELEX : CASCO K32776

Specifications subject to change for improvement without prior notice.

