

AD-series

Simple Weighing Scale



- Easy-to-Operate, Compact Design
- Easy-to-Read VFD Display
- Stainless Steel Platter
- Soft Touch Tact Switch



▲ AD-T (Baby Scale)



CAS

AD Series Simple Weighing Scale

FEATURES

- Simple Weighing Scale
- Function Key : On/Off, Zero, Tare, Hold (kg/lb)
- Soft Touch Tact Switch
- Easy-to-Read VFD Display
- Stainless Steel Platter
- Auto Span Adjustment
- Auto Zero Tracking

SPECIFICATIONS

Model	AD series
Weighing Capacity	2.5kg × 0.5g, 5kg × 1g, 10kg × 2g 3kg × 1g, 6kg × 2g, 15kg × 5g, 30kg × 10g
Measurement Type	Load Cell
Power Source	AC 110/220V, 50/60Hz
Power Consumption	Approx. 10W
Operating Temperature	- 10°C ~ +40°C
Platter Size (mm)	340(W) × 215(D)
Dimensions (mm)	350(W) × 325(D) × 105(H)
Product Weight	4.7kg

DISPLAY & KEYBOARD



KEY SPECIFICATIONS

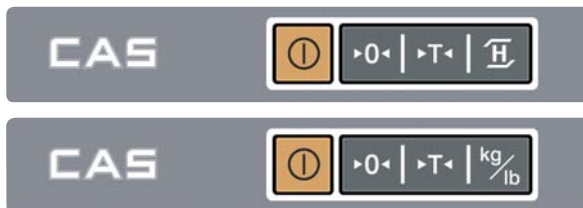

CAS

www.globalcas.com

CAS BLDG., #440-1, SUNGNAE-DONG
GANGDONG-GU, SEOUL, KOREA
TEL : 82-2-2225-3500
FAX : 82-2-475-4668

AD DIMENSIONS

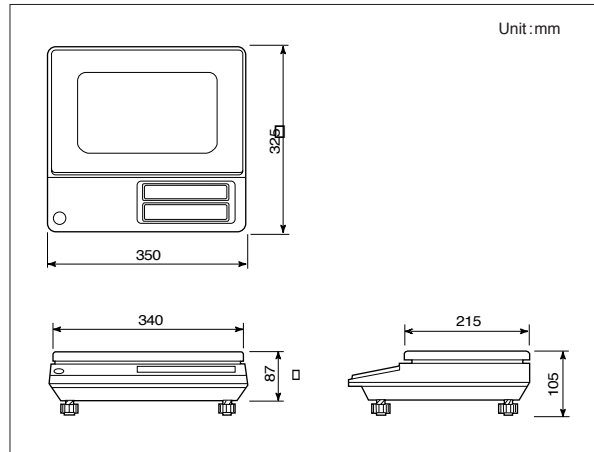

AD-T TRAY DIMENSIONS

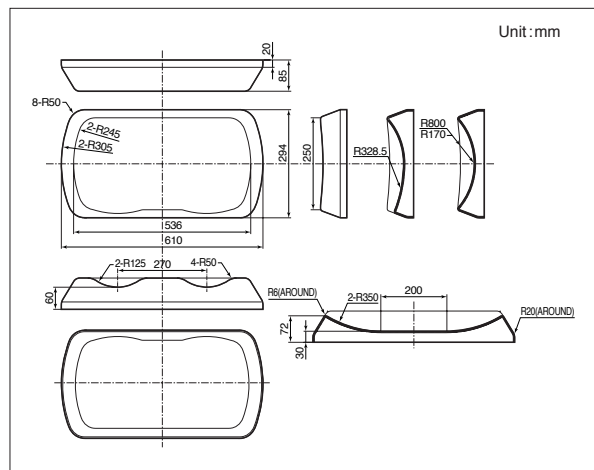

OPTIONS

- RS-232C Interface
- Baby Tray (AD-T) : 610(W) × 294(D) × 85(H) mm
- Large Tray : 440(W) × 275(D) × 50(H) mm
- Printer : DEP-50 (Receipt printer)